

# INSIGHT INTO THE SANS TECHNIQUE

Boualem Hammouda

National Institute of Standards and Technology  
Center for Neutron Research

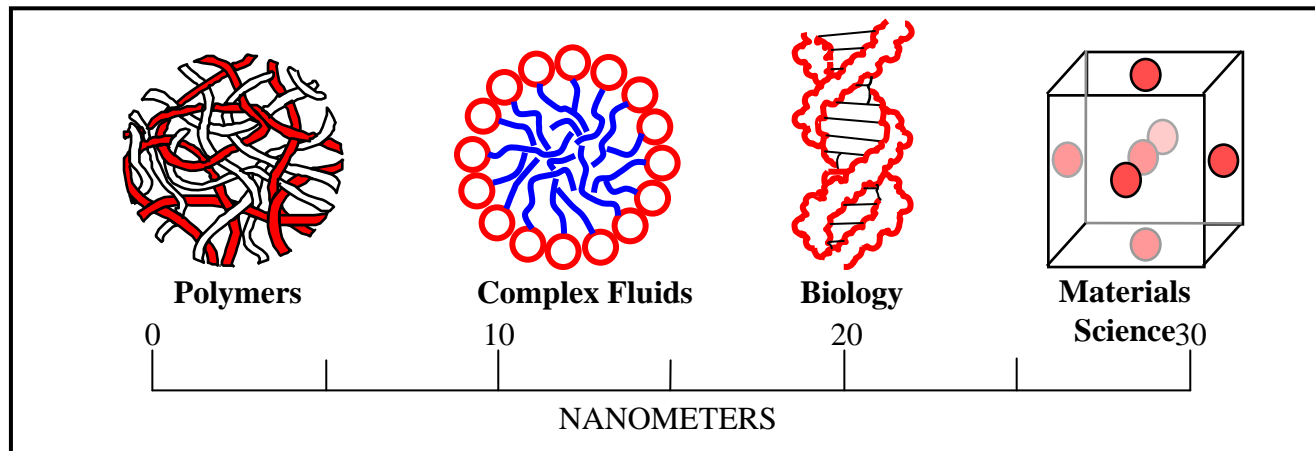

# OUTLINE

- 1. NIST Guide Hall and Elements of Neutron Scattering
- 2. SANS Instrument Components
  - Velocity Selectors
  - Neutron Detectors
- 3. Typical SANS Spectra
- 4. SANS Data Modeling
  - The Random Phase Approximation
  - The Ornstein-Zernike Equation
- 5. SANS Research Topics
  - A - Polymer Solution
  - B - Pressure Effect
  - C - Crystalline Lamellae
  - D - Protein Complex
- 6. Gallery of SANS Data Images
- 7. SANS User Statistics and Final Words

# 1. NIST GUIDE HALL

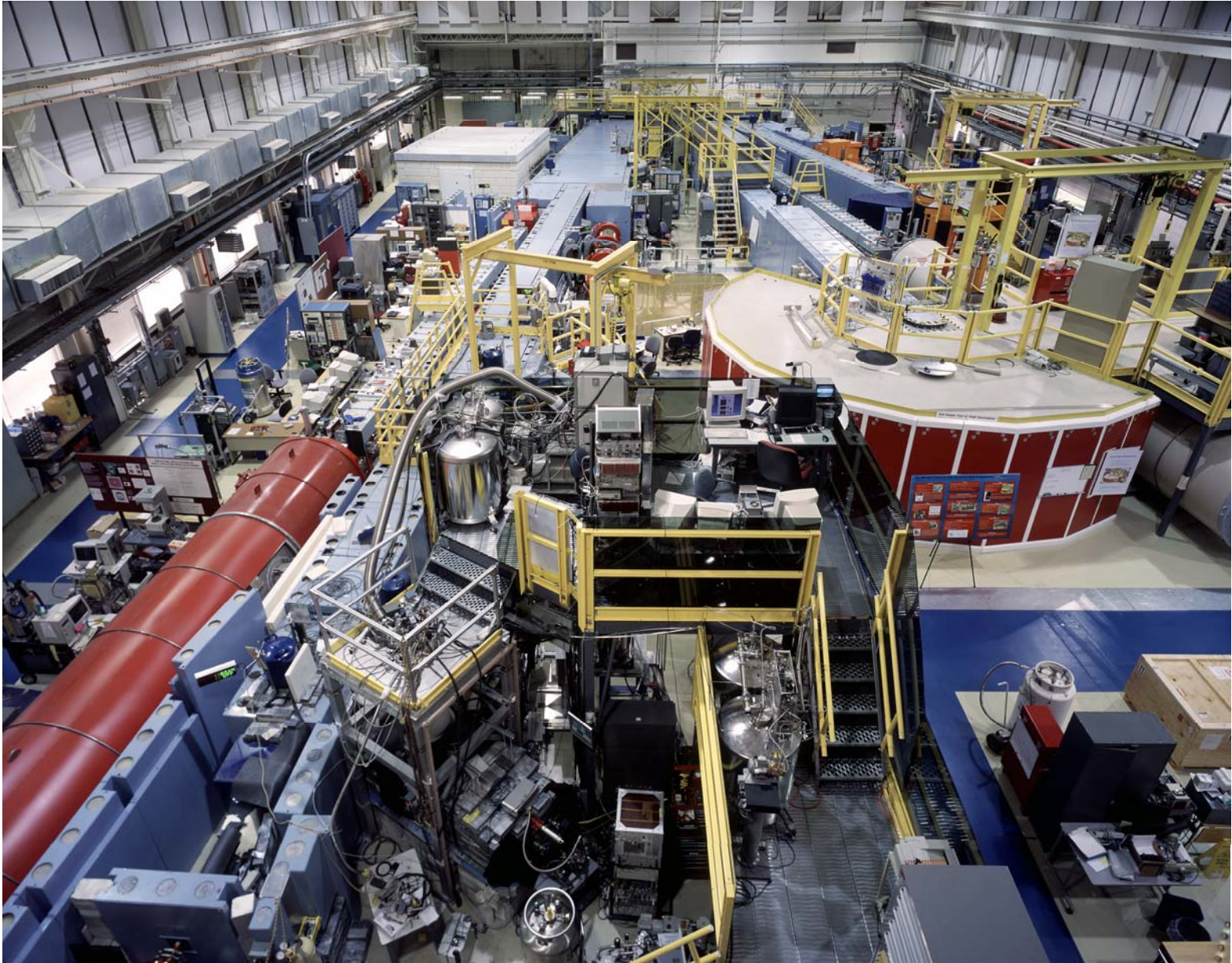

# NEUTRON CROSS SECTIONS

$$I(Q) = \frac{d\Sigma_{\text{coh}}(Q)}{d\Omega} + \frac{d\Sigma_{\text{incoh}}}{d\Omega}$$

COHERENT

Contrast factor =  $(\rho_A - \rho_B)^2$

INCOHERENT

-- spin incoherence  
-- composition disorder

# SMALL-ANGLE NEUTRON SCATTERING

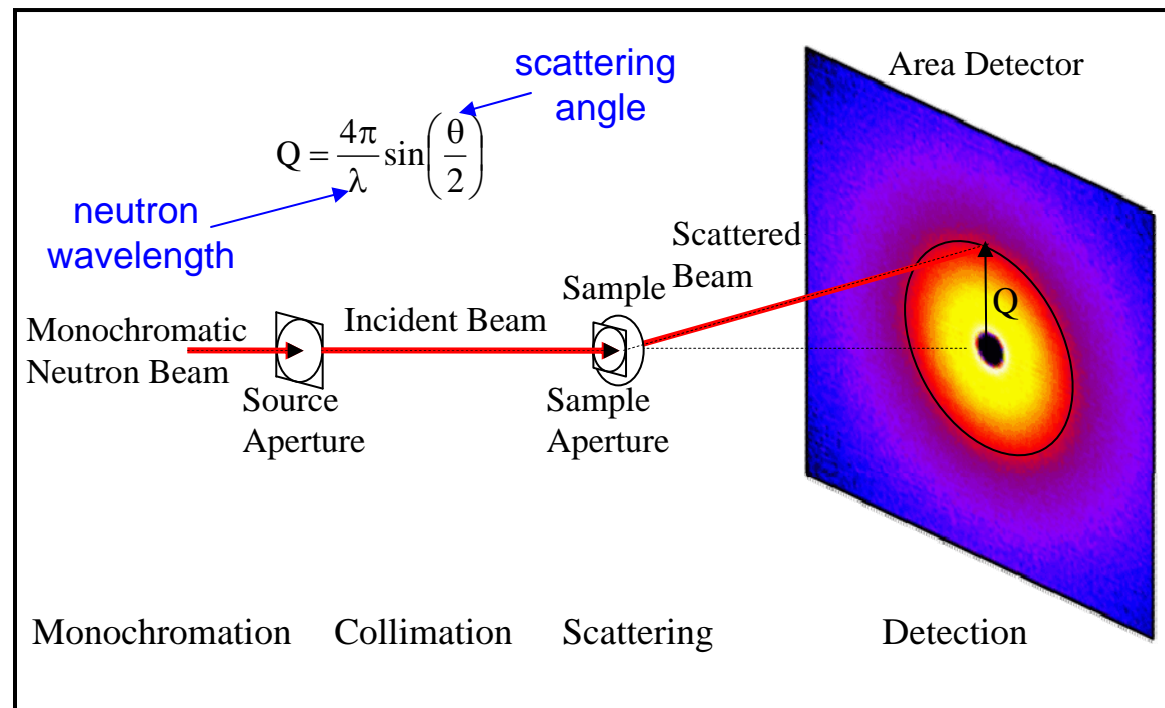

# The NG3 SANS Instrument



# 3. SANS INSTRUMENT COMPONENTS

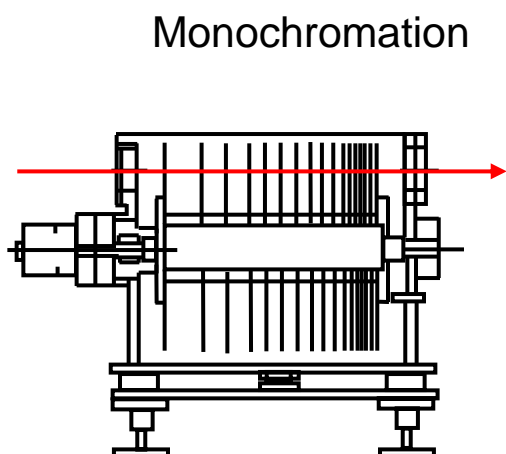
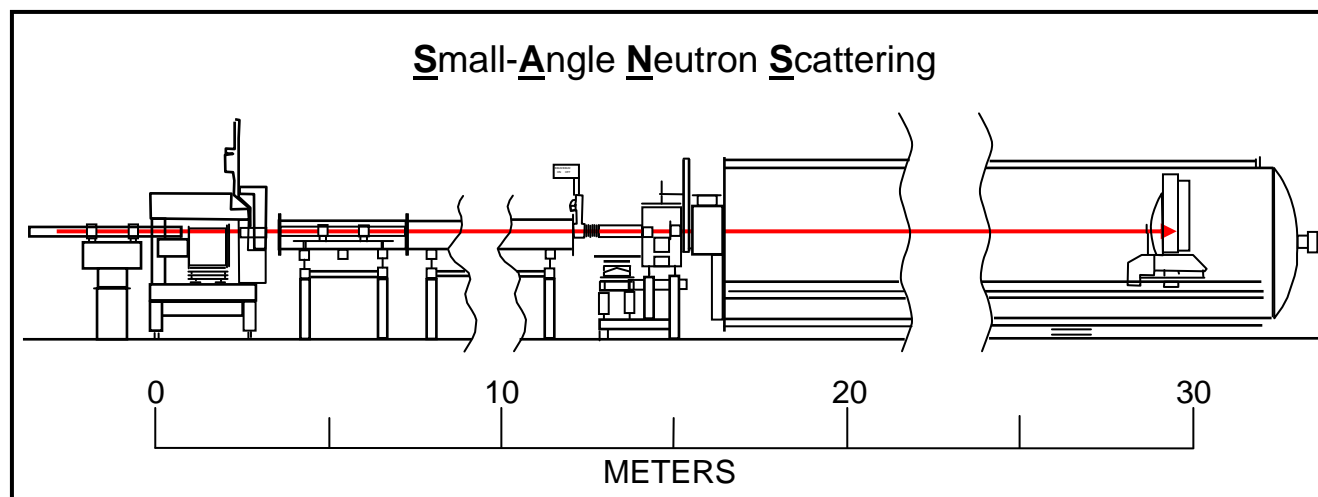

Multidisk velocity selector

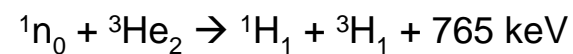
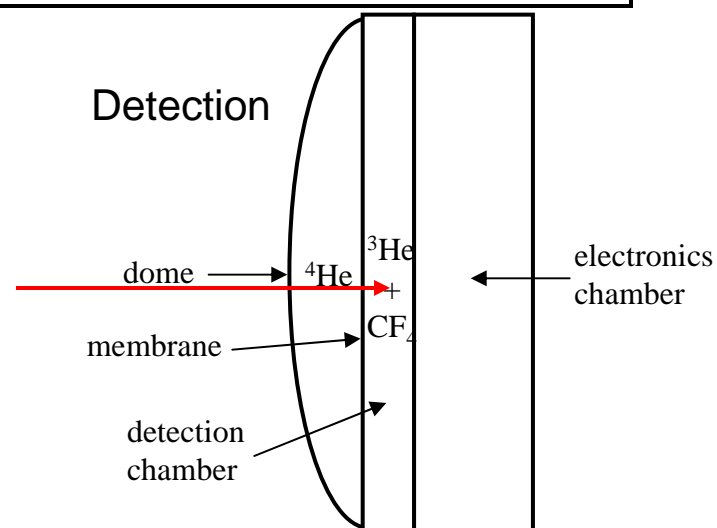

High count rate neutron detector



**Neutron area detector**

**Velocity selector**

**NG3 SANS scattering vessel**



# 4. TYPICAL SANS SPECTRA

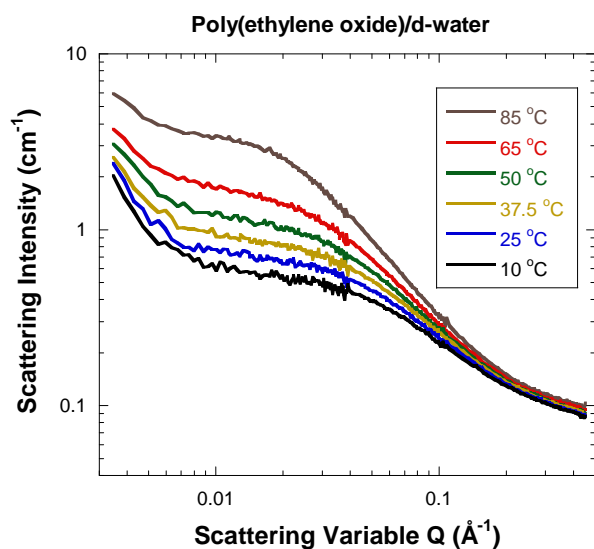

Polymer Solution

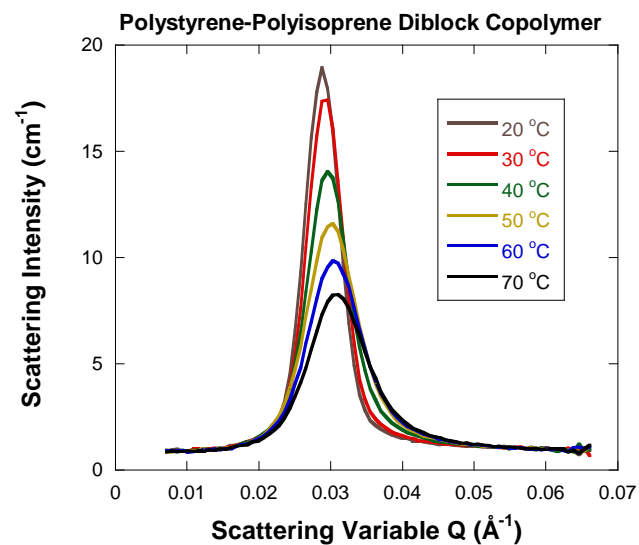

Copolymer

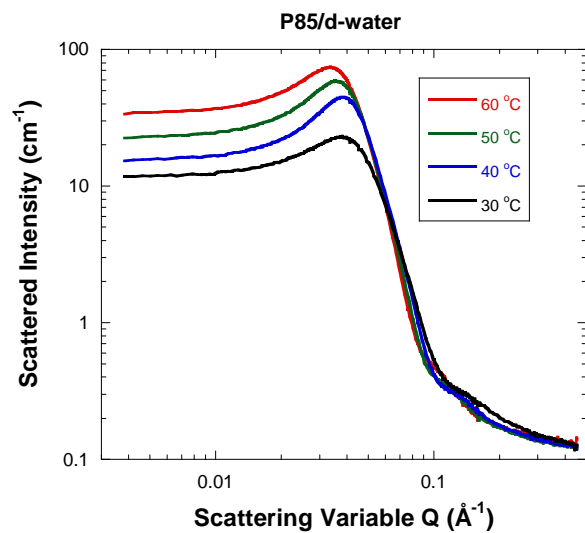

Complex Fluid

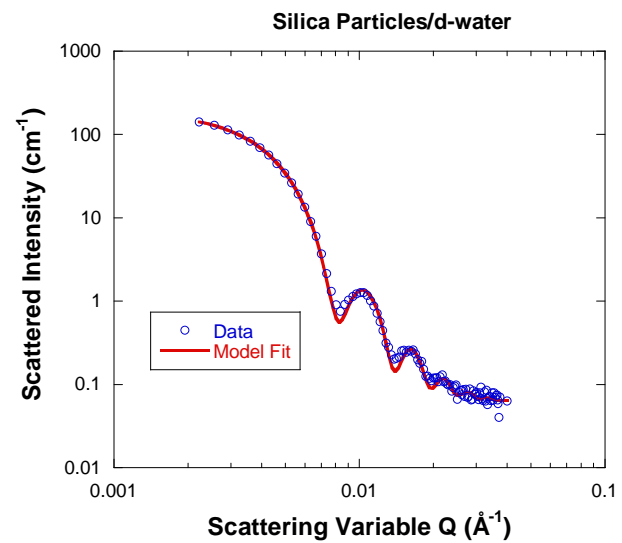

Silica Particles

# 4. SANS MODELING

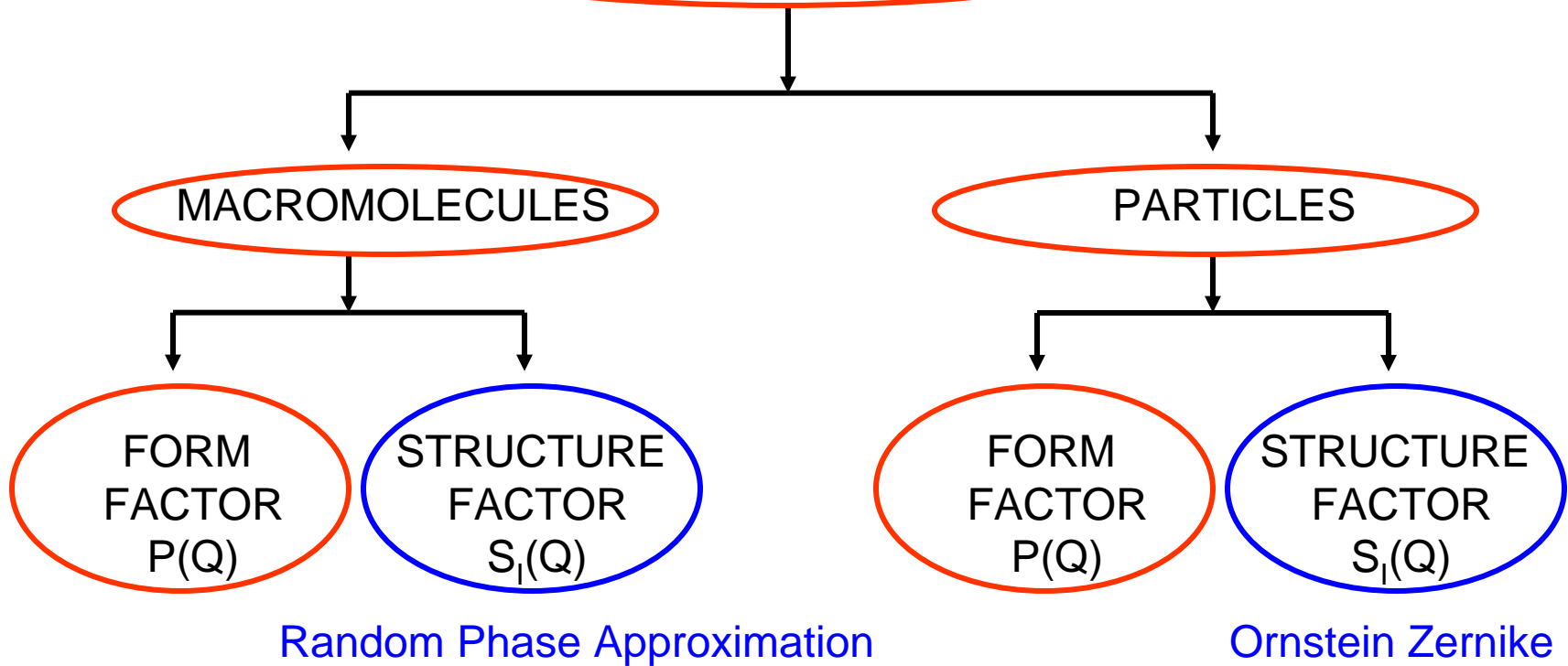

$$\frac{d\Sigma(Q)}{d\Omega} = \left( \frac{N_A}{V} \right) (\rho_A - \rho_B)^2 V_A^2 P(Q) S_I(Q)$$

↑ cross section    ↑ number density    ↑ contrast factor    ↑ particle volume    ↑ form factor    ↑ structure factor

## 5. SANS RESEARCH TOPICS

A - Polymer Solution

B – Pressure Effects

C – Crystalline Lamellae

D – Protein Complex

A - Polymer Solution



# SANS From hPoly(Ethylene Oxide)/D<sub>2</sub>O

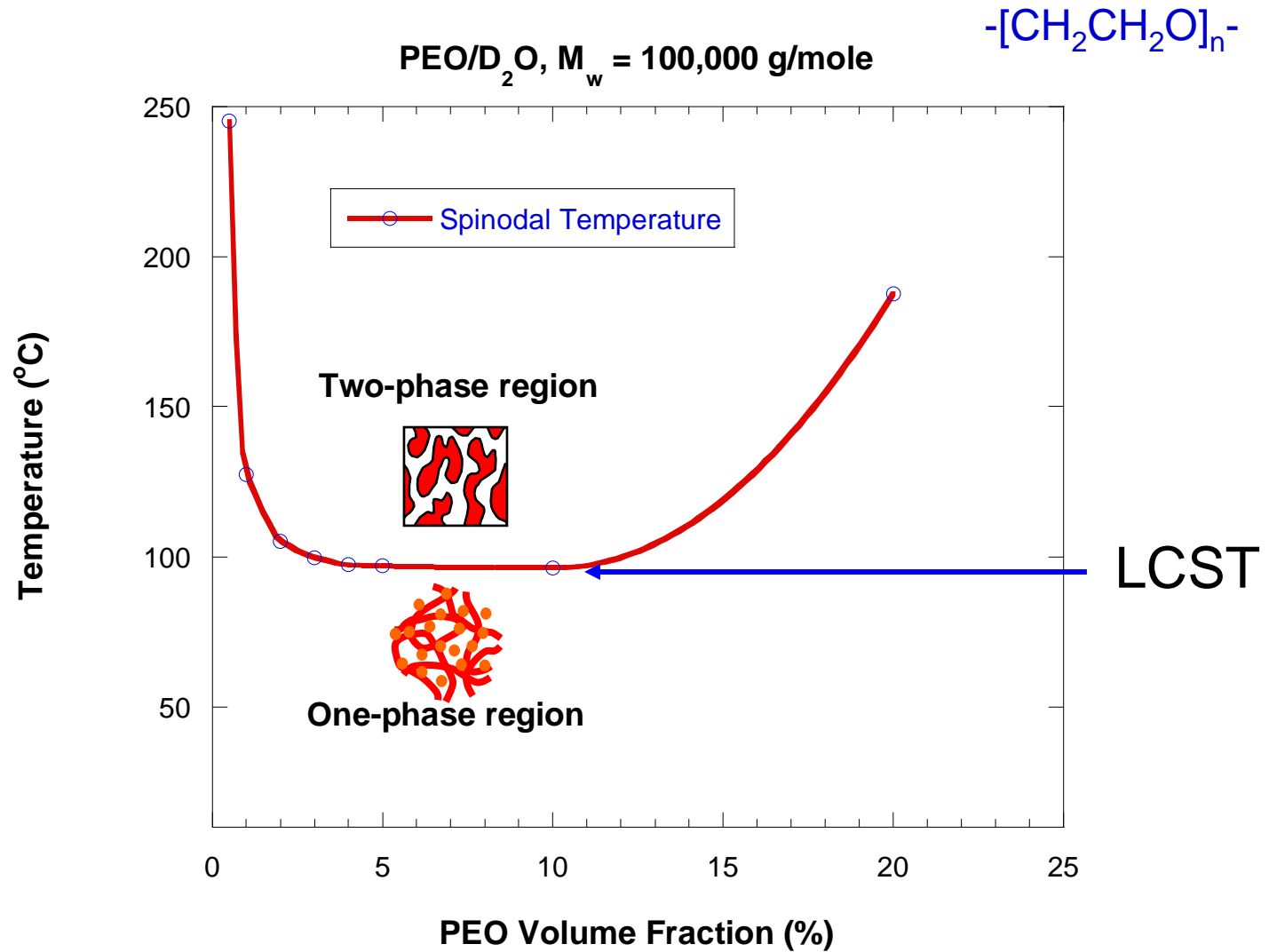

# The Contrast Match Method

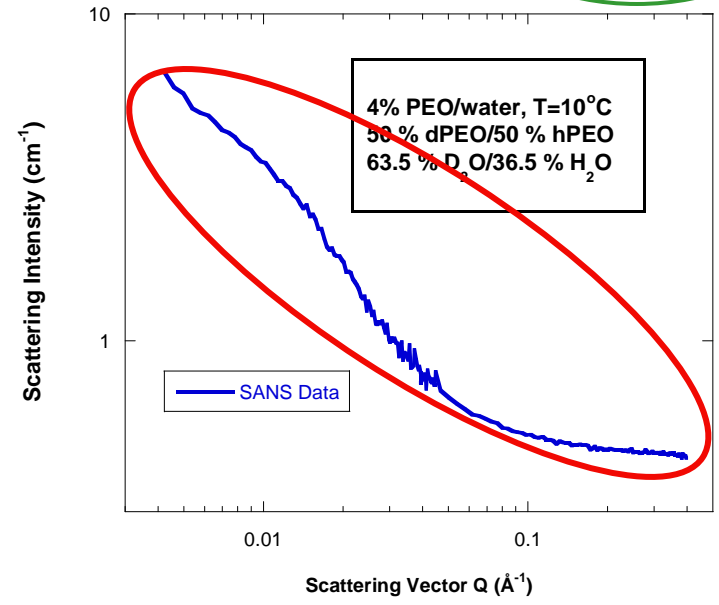
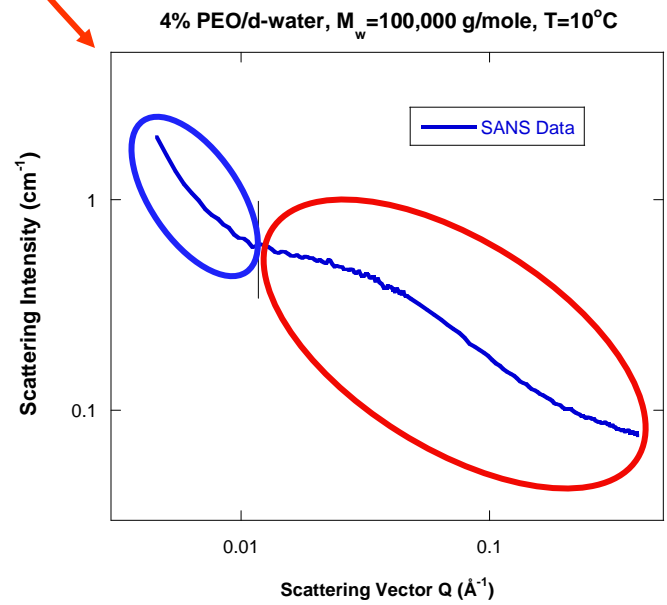
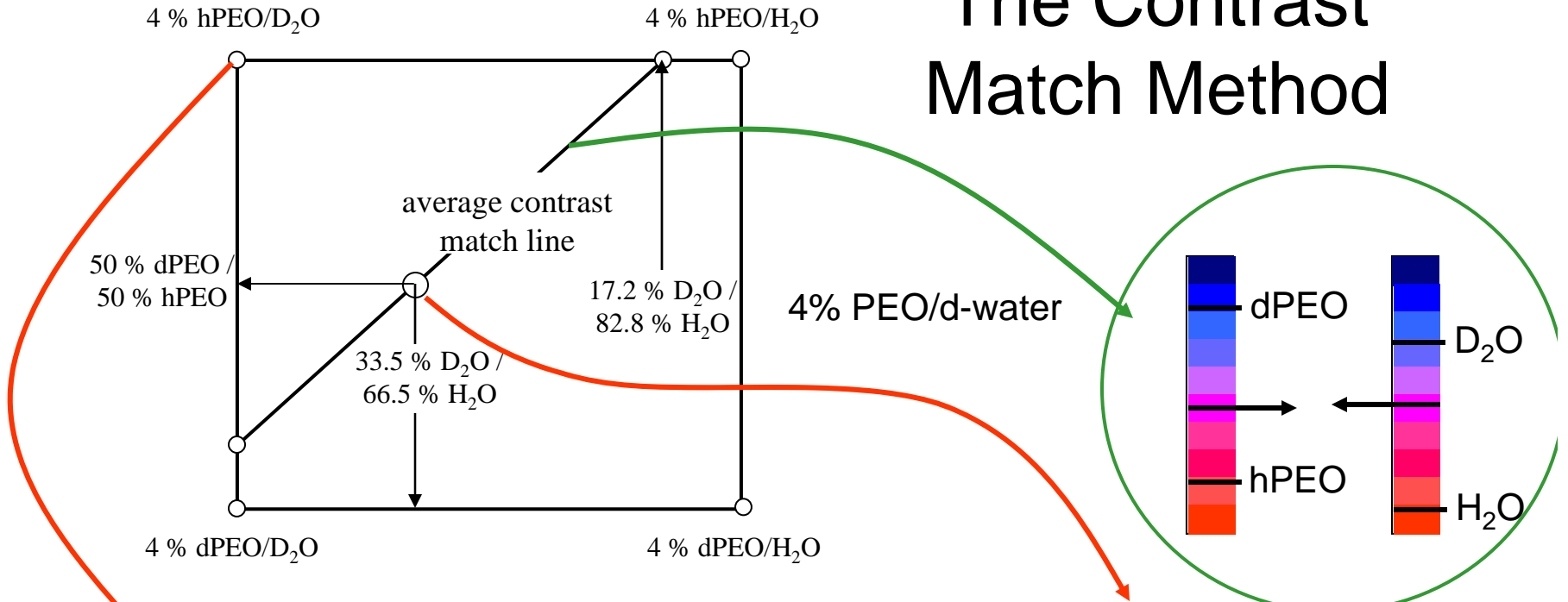

## B – Pressure Effects

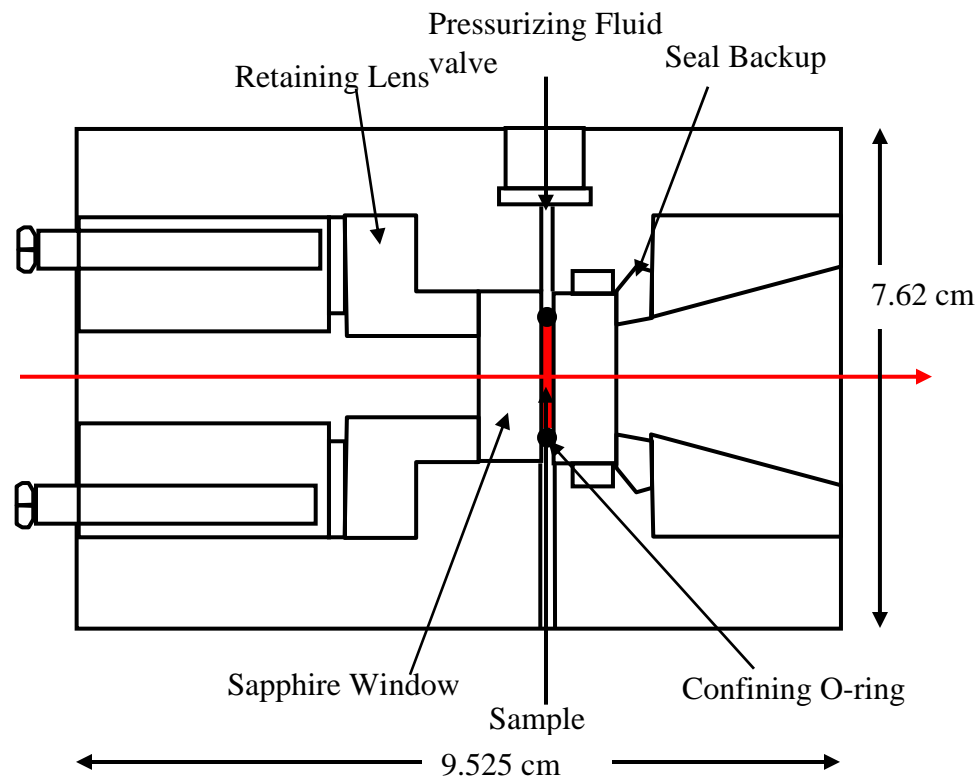

# Phase Shifts

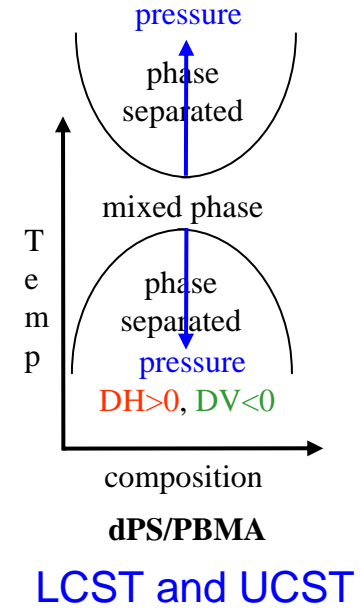
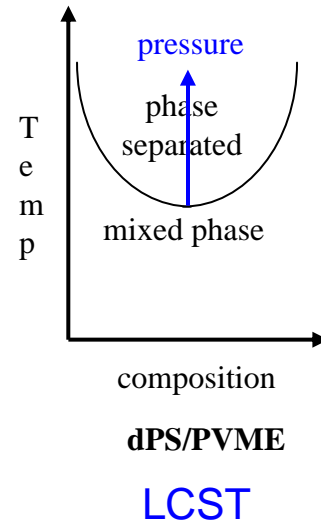
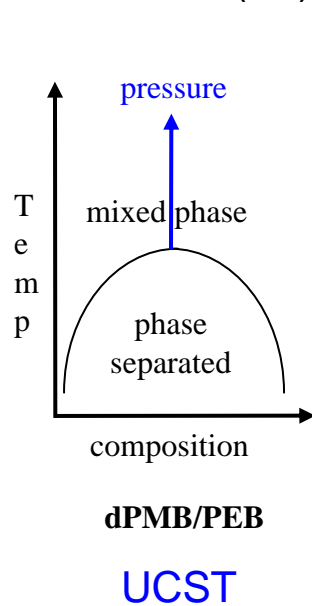
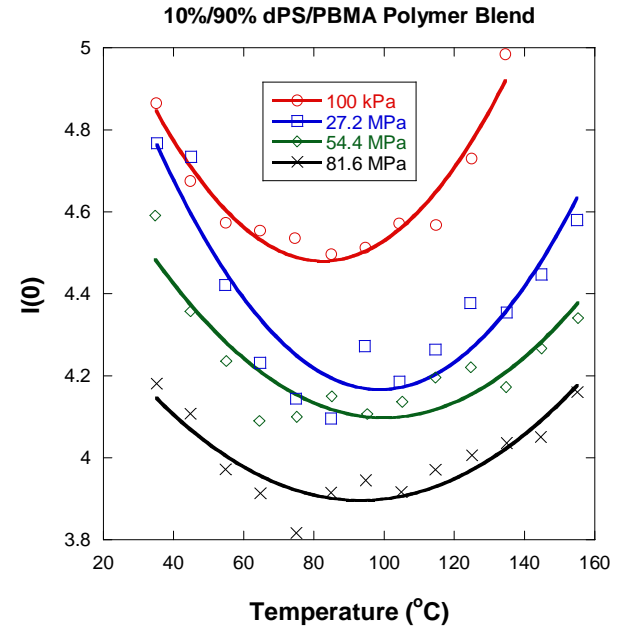
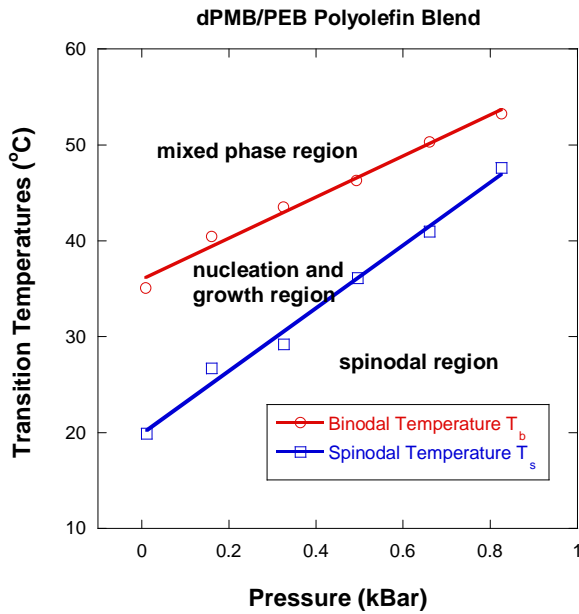



# The Clausius-Clapeyron Equation

$$\frac{dT}{dP} = \frac{\Delta V}{\Delta H}$$

Volume change upon mixing

Enthalpy change upon mixing

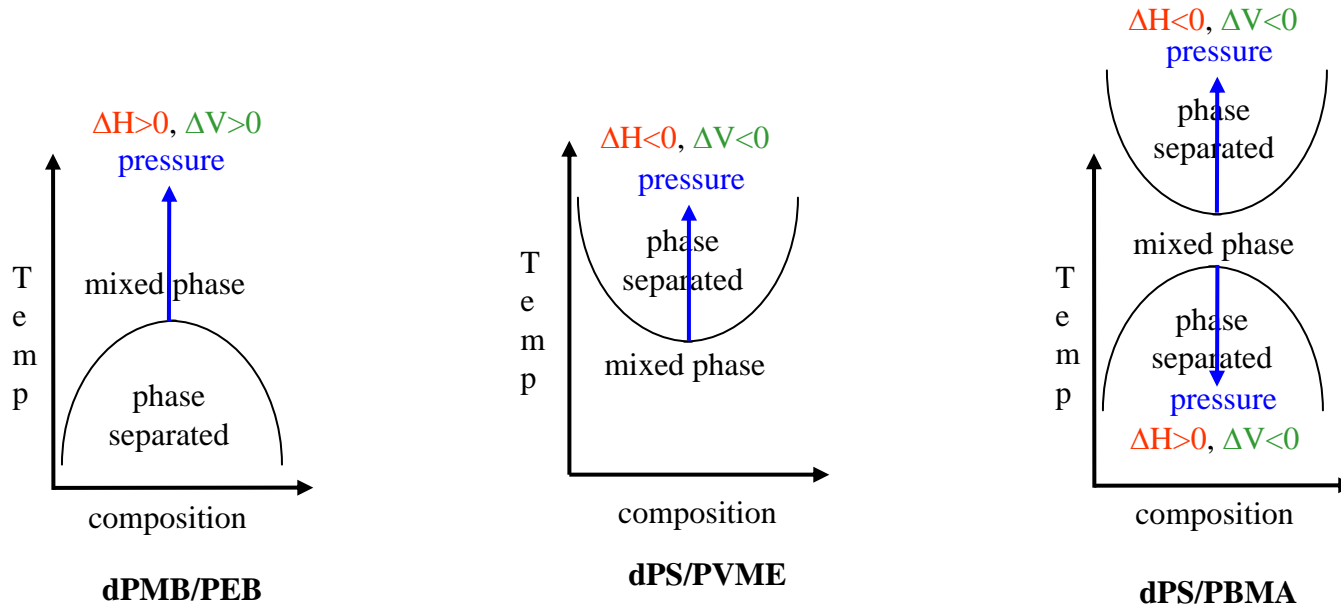

## C – Crystalline Lamellae

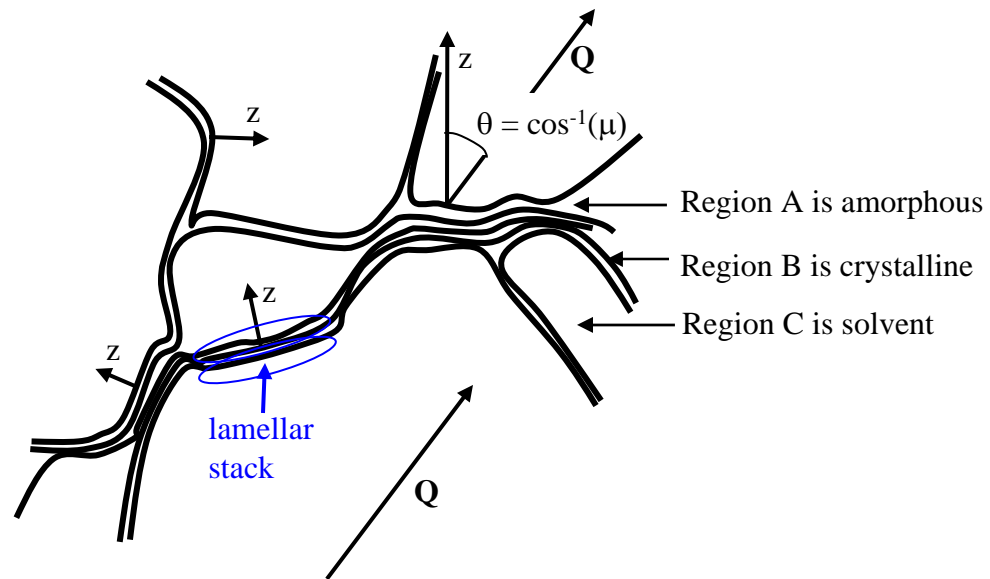

# Crystalline Lamellae

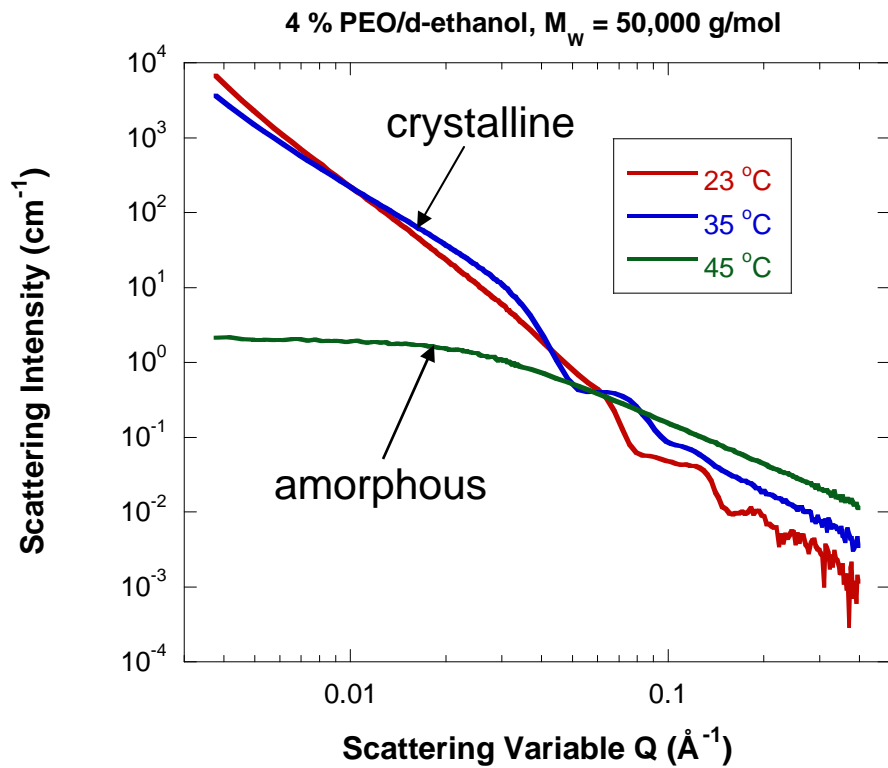

SANS

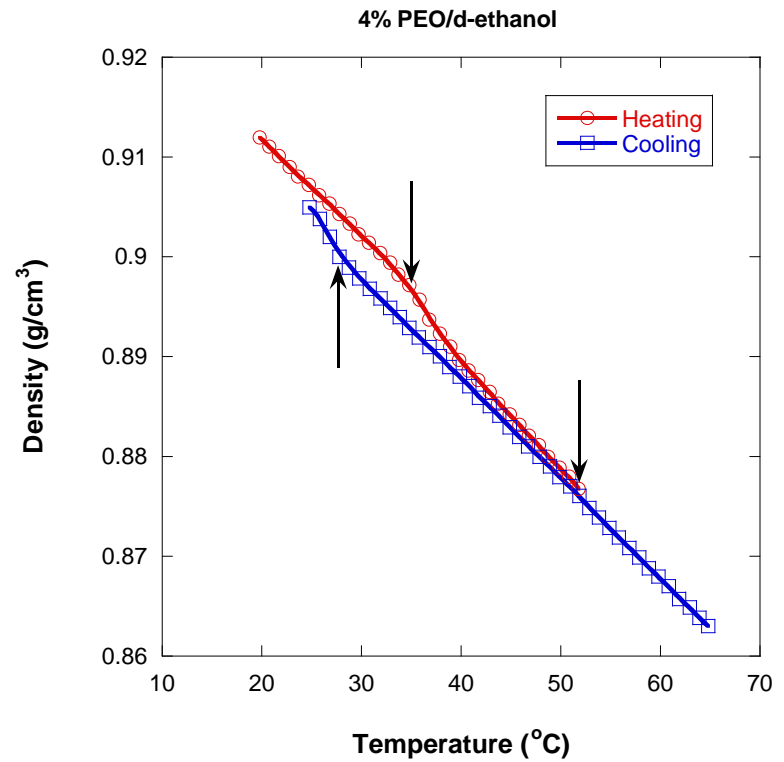

Density Measurement

# Model

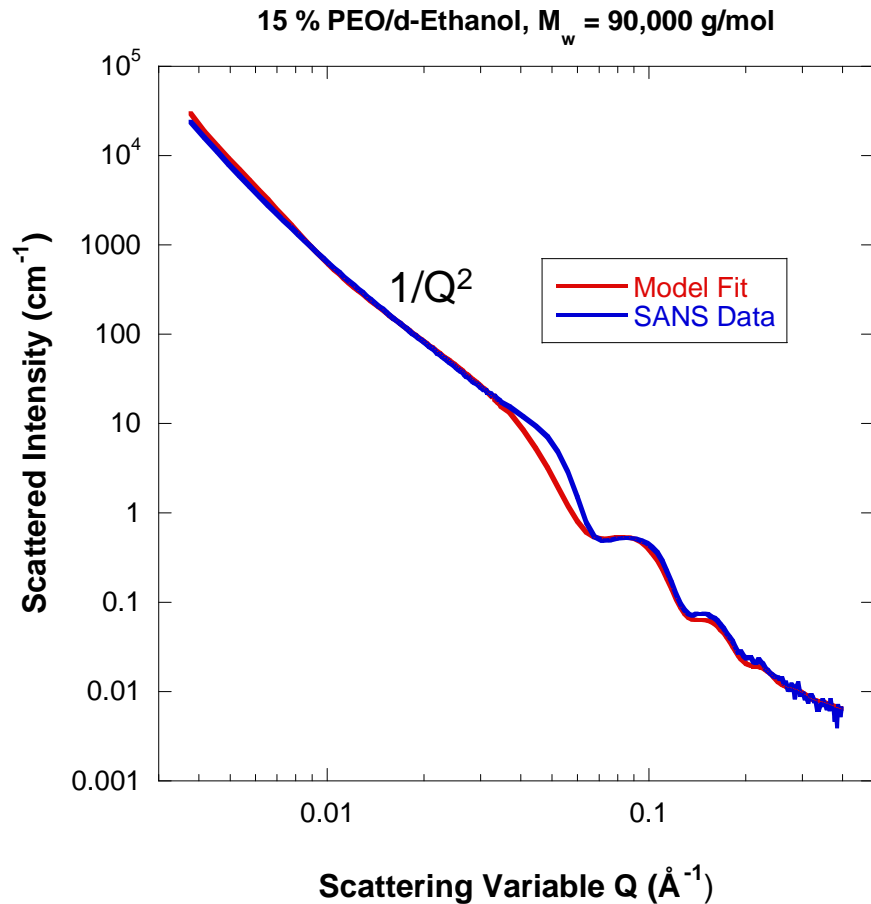

## Lamellar Stack Model

Lamellar stacks volume fraction  $\phi_S = 0.36$

Lamellae radius  $R = 10,757 \text{ \AA}$

Thickness of the amorphous region  $L_A = 3 \text{ \AA}$

Lamellar thickness  $L_B = 50 \text{ \AA}$

SLD of the amorphous region  $\rho_A = 4.15 \cdot 10^{-6} \text{ \AA}^{-2}$

SLD of the crystalline region  $\rho_B = 7.67 \cdot 10^{-7} \text{ \AA}^{-2}$

SLD of the d-ethanol region  $r_S = 6.07 \cdot 10^{-6} \text{ \AA}^{-2}$

Number of lamellae per stack  $N_L = 6.86$

# Morphology

Transmission Electron  
Microscopy

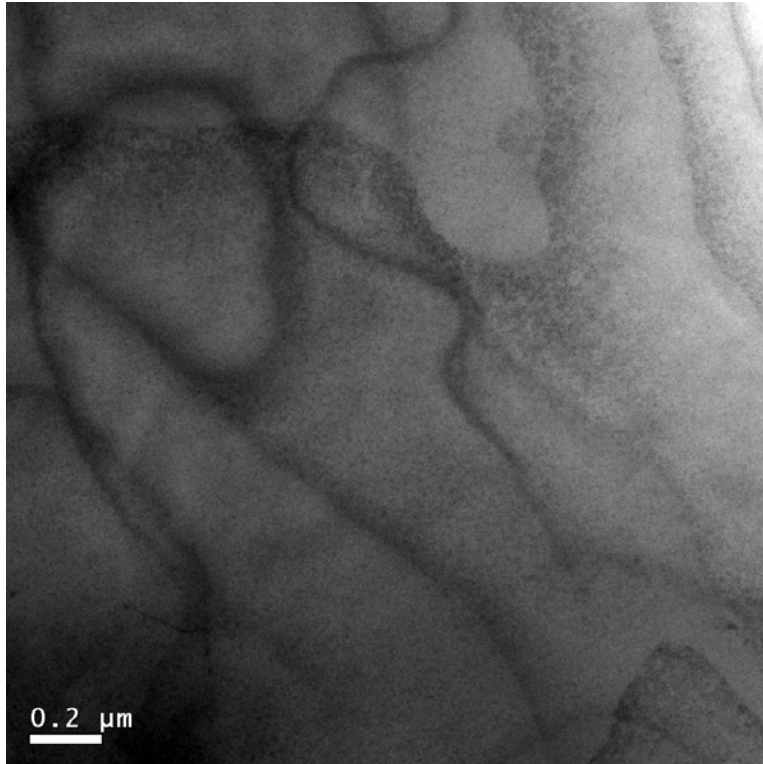

Electron Diffraction

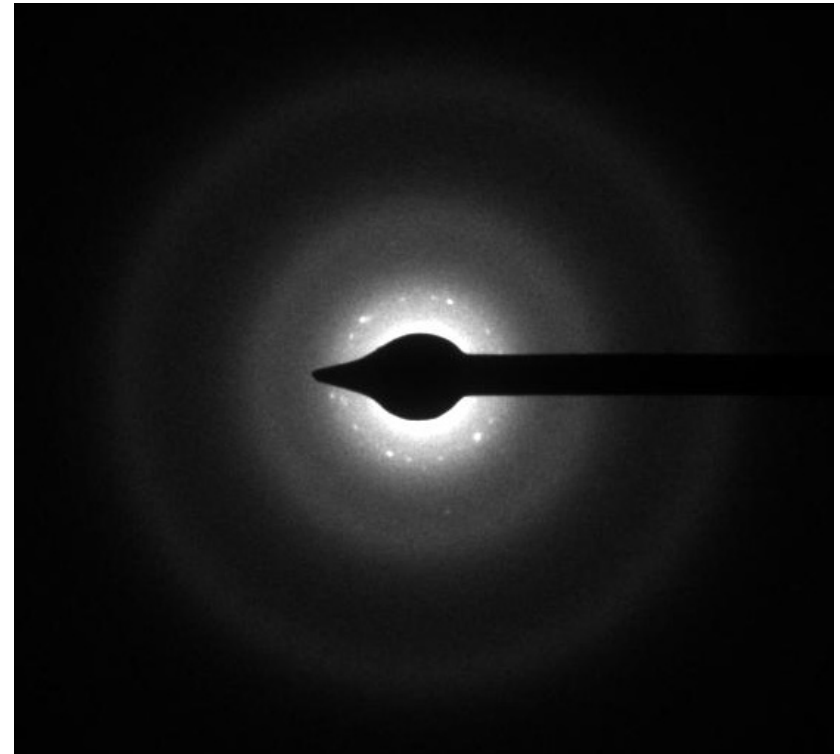

# D – Protein Complex

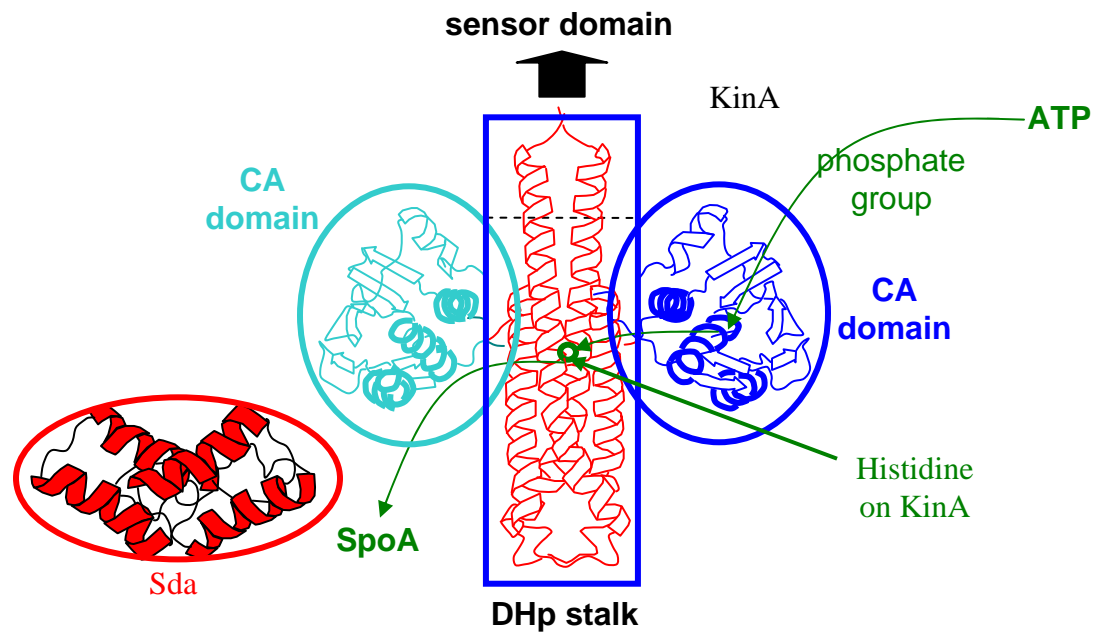

# SAXS Data

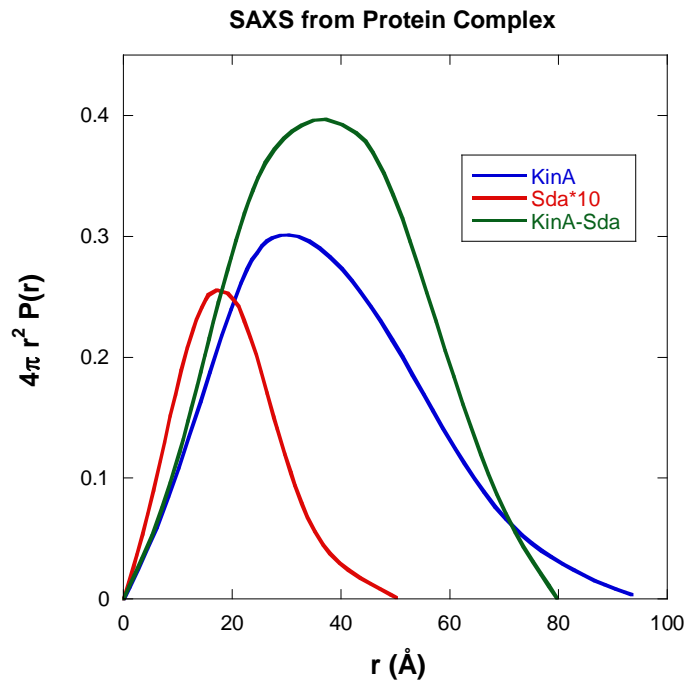

# KinA-Sda Complex

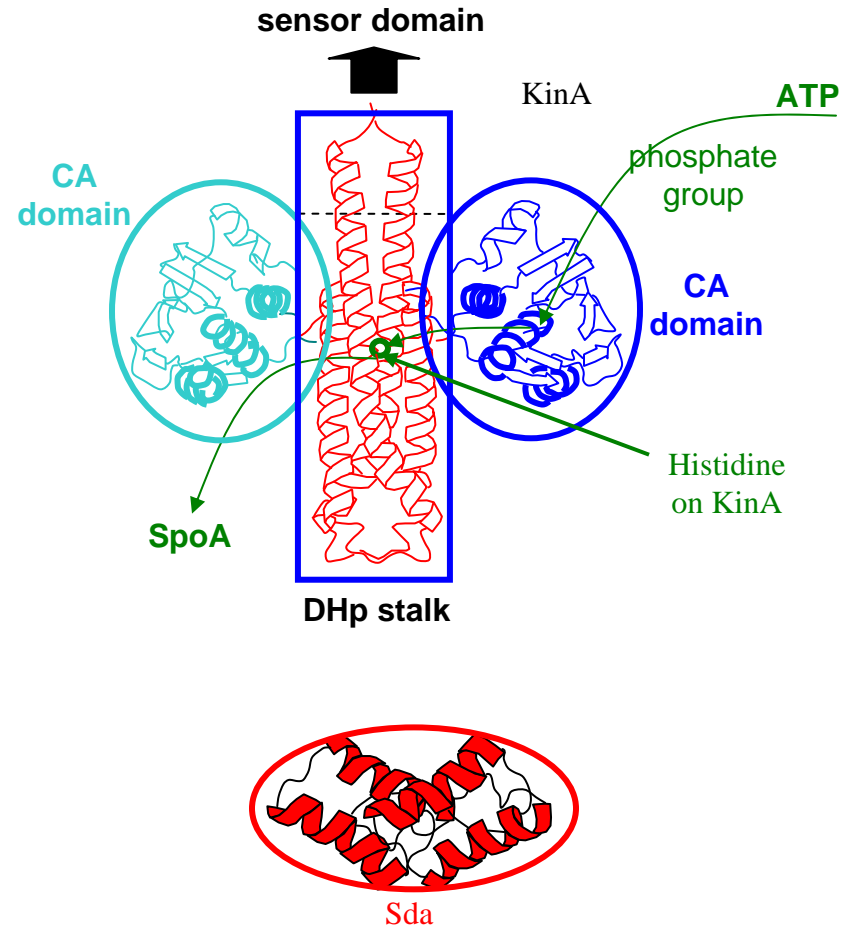

# SANS Data

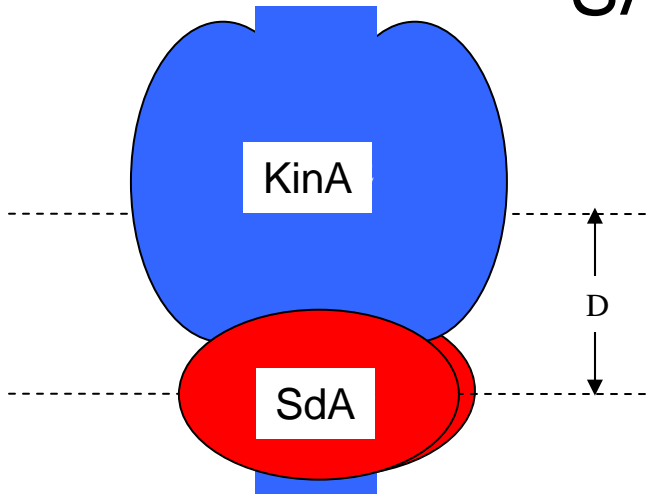

# KinA-Sda Complex

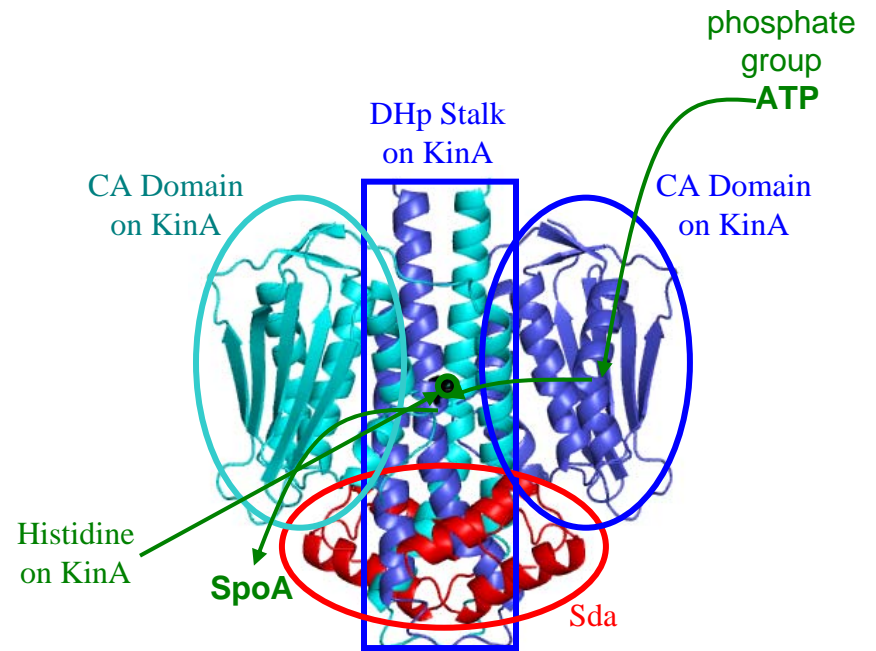
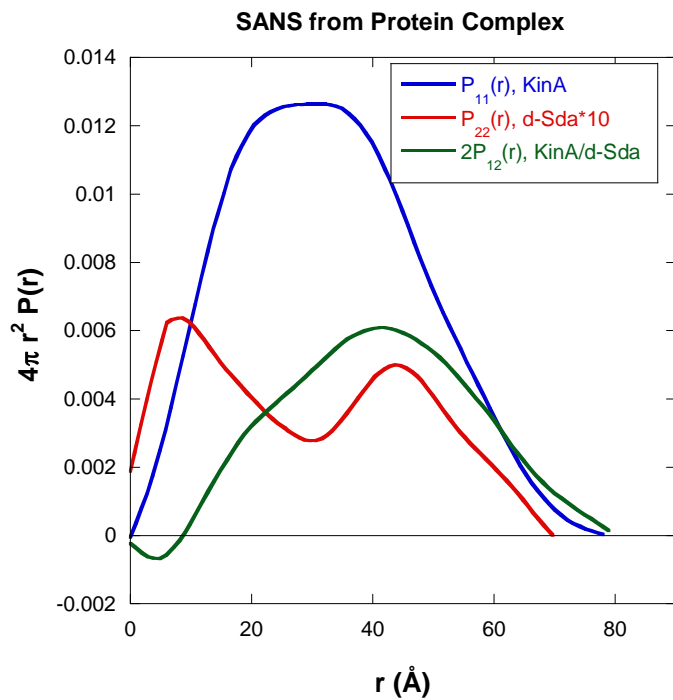



## 6. GALLERY OF SANS DATA IMAGES

# Sheared Multilayer Vesicles

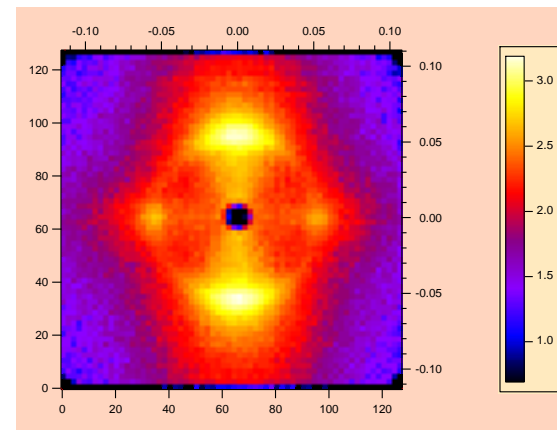
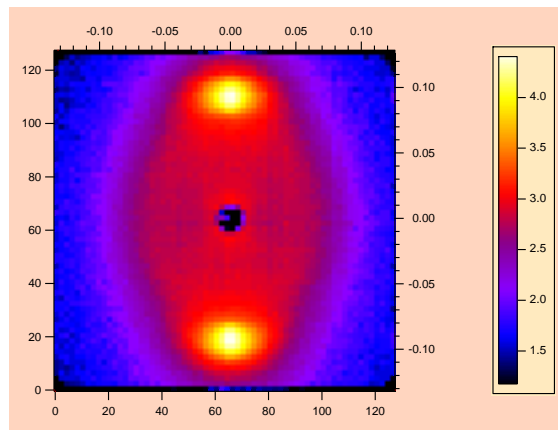
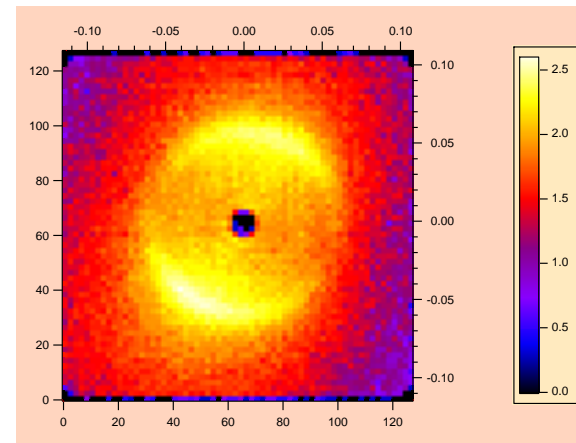
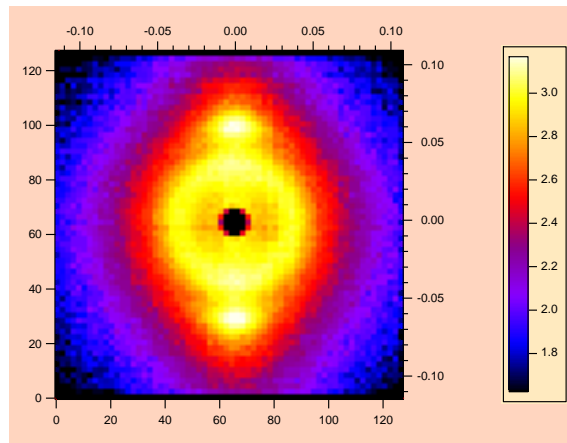

# The Butterfly Pattern

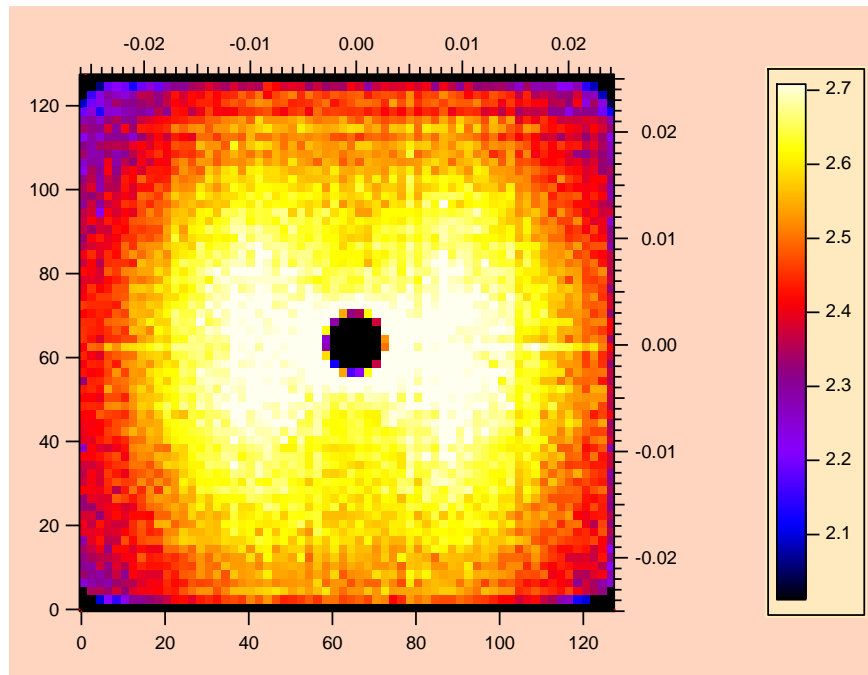

# Packed Spheres

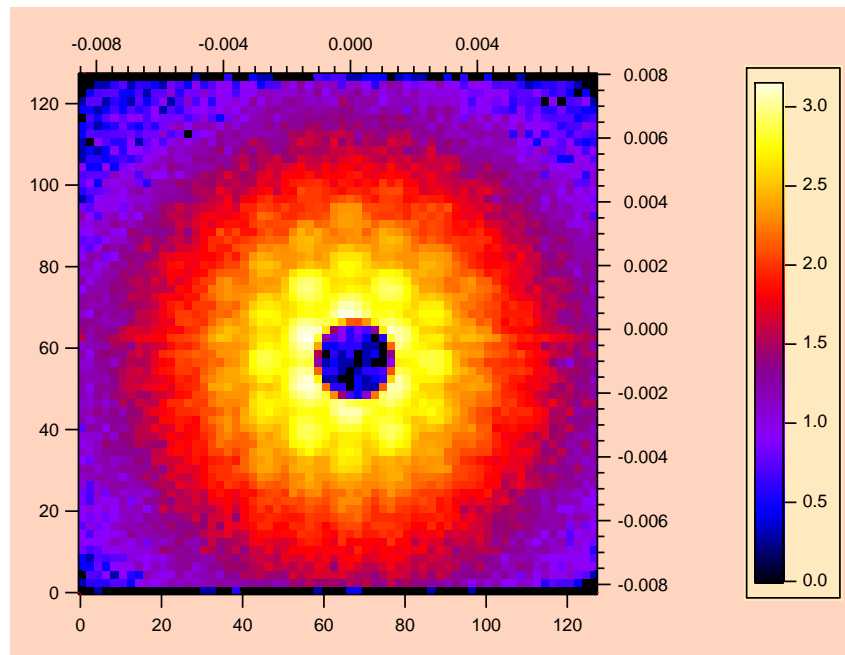

# Kangaroo Tail Tendon

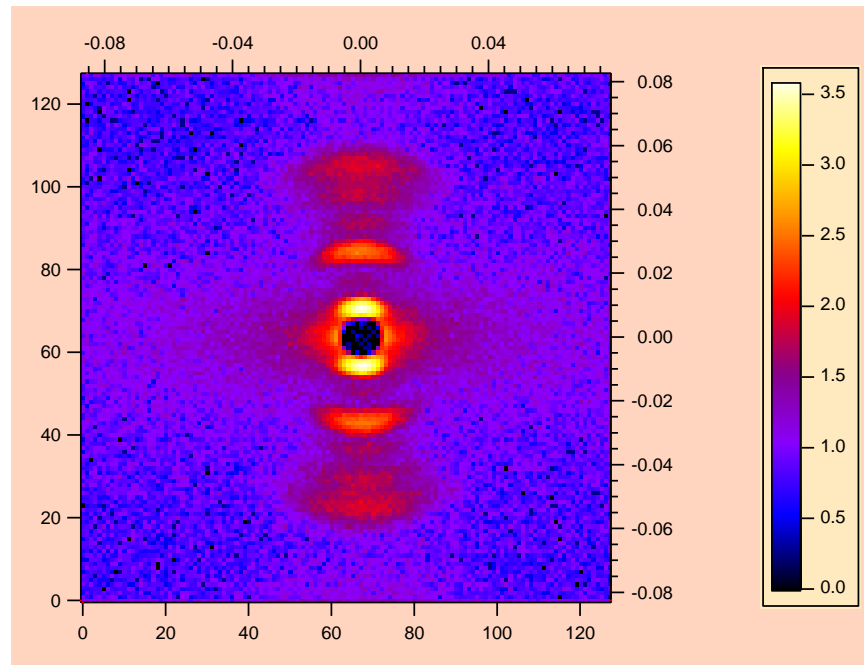

# Twinned Crystal

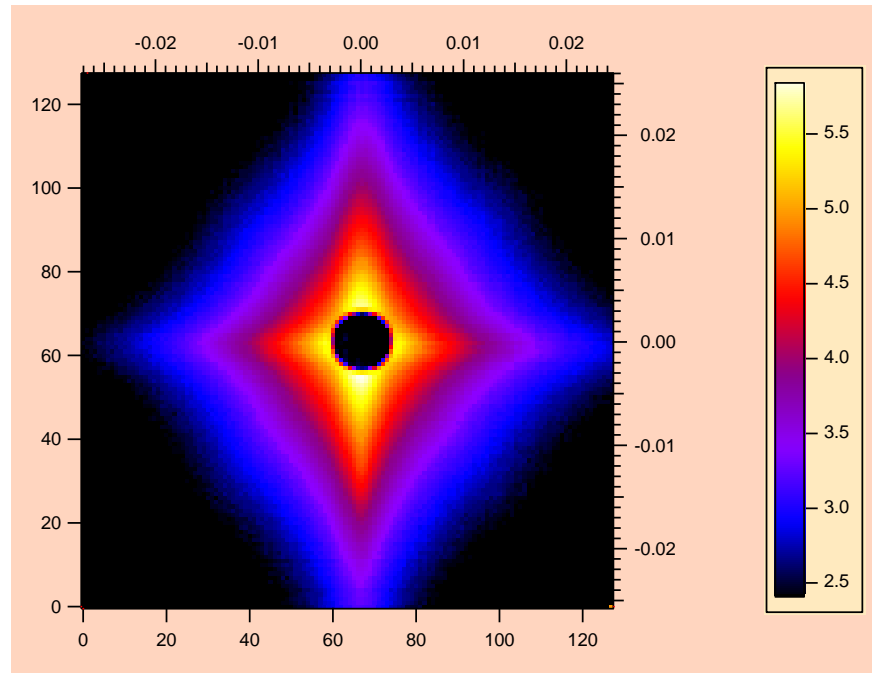

# Peptides Oriented in Membranes

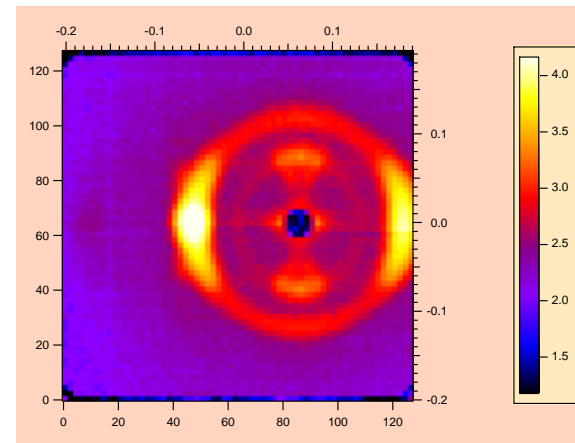
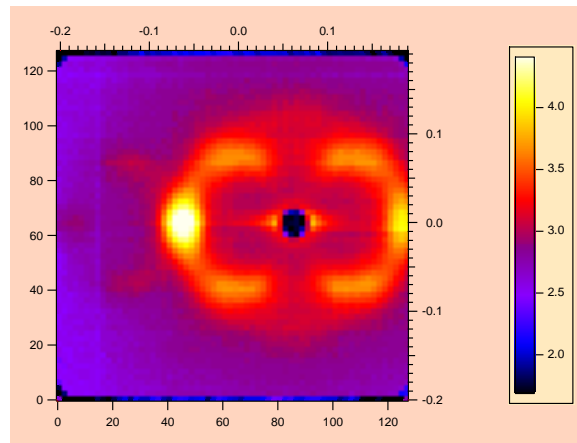
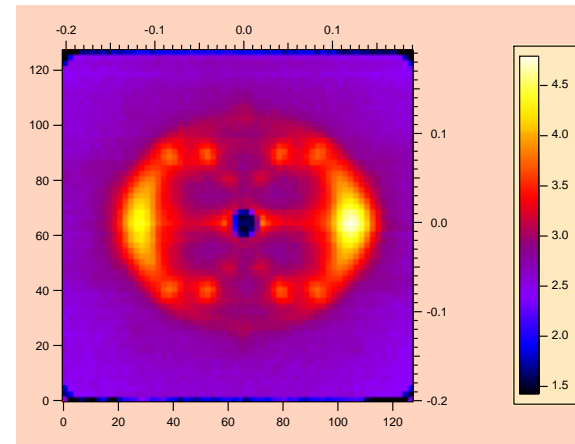
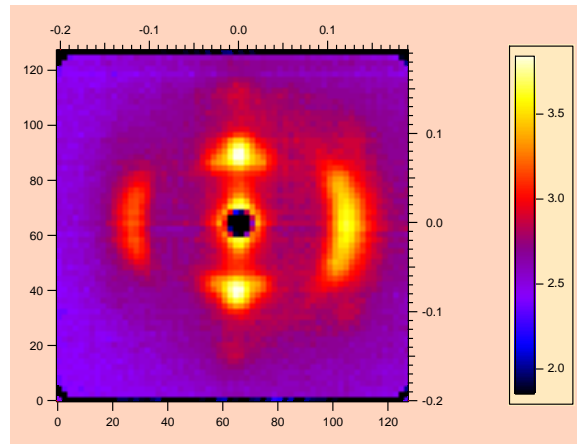

# 7. SANS USER STATISTICS

## SANS PROPOSALS

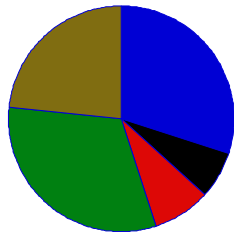

Year 1999

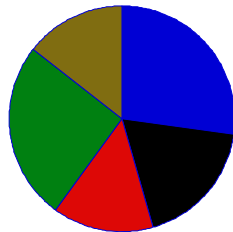

Year 2003

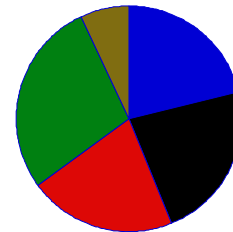

Year 2007

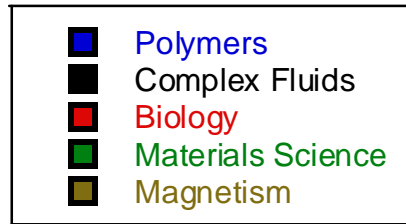

## SANS PUBLICATIONS

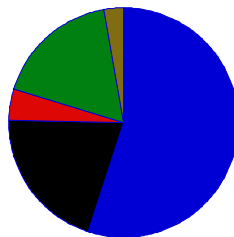

Year 2001

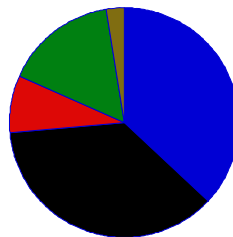

Year 2003

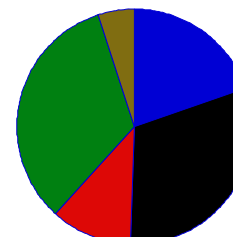

Year 2007



# FINAL WORDS

## THE SANS PROGRAM AT NIST

200 experiments per year

15 theses per year

70 publications per year

## OTHER CHARACTERIZATION METHODS

Small-Angle X-Ray Scattering

Electron Microscopy

## ACKNOWLEDGMENTS

Derek Ho, Nitash Balsara, Jill Trewhella,  
Steve Kline

PROBING NANOSCALE STRUCTURES –THE SANS TOOLBOX

[http://www.ncnr.nist.gov/staff/hammouda/the\\_SANS\\_toolbox.pdf](http://www.ncnr.nist.gov/staff/hammouda/the_SANS_toolbox.pdf)